



TORNOS

*We put you
on the road to
greater quality,
safety and
sustainability.*

AUTOMOTIVE

Passenger cars

CO₂ emissions and fuel consumption, normalized to NEDC

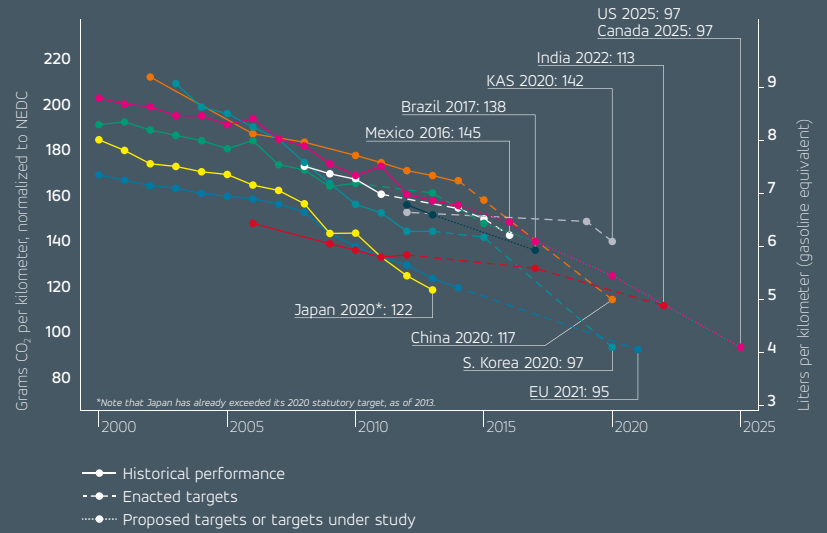

Global light vehicle production

Still focused in emerging markets

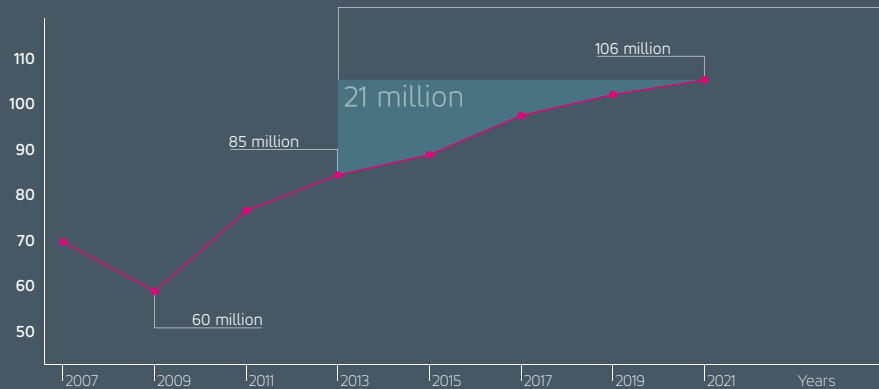

Passenger cars

Overall and annual required rates of CO₂ reduction

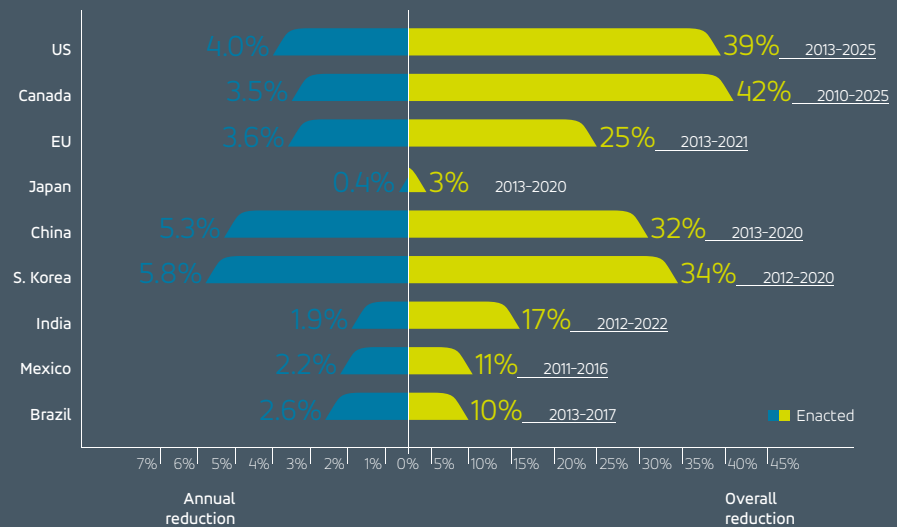

Powertrain technology trends

North America installation

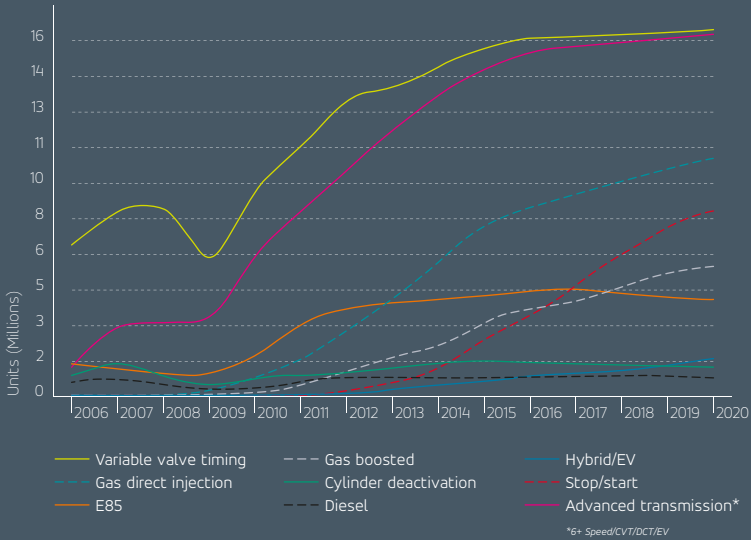

- VVT almost standard on any new engine; many migrating to advanced designs
- GDI and gas boosting both ramp up quickly.
- Stop/start technology growing, helped by CAFE off-cycle credits
- Diesel and hybrid/EV still relatively low-volume players in North American market, though Hybrids gain traction late in the decade

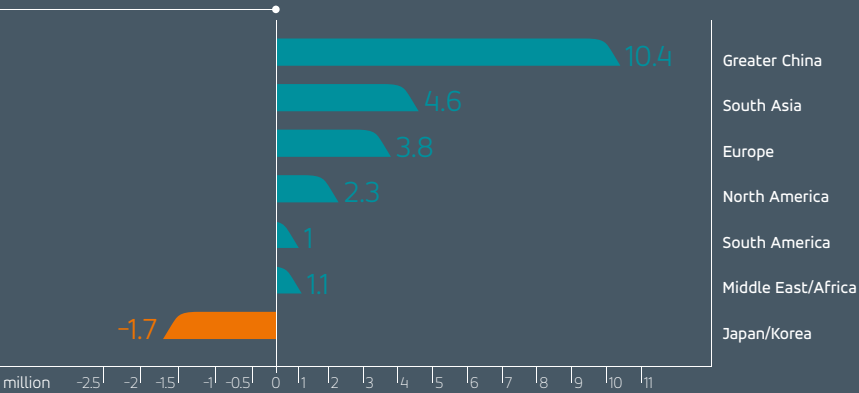

Greener, safer, smarter

KEY MEGATRENDS DRIVE DEMAND FOR MORE FUEL EFFICIENT, SAFE, AND INTELLIGENT VEHICLES. AS A RESULT, THE GLOBAL AUTOMOTIVE INDUSTRY IS POISED FOR GROWTH.

Driven by an array of global macroeconomic trends—changing demographics, globalization and the emergence of future markets, climate change, and an ever-increasing pace of technological change and innovation¹—the road ahead for the global automotive industry is paved with both opportunities and challenges. Key megatrends—global, sustained and macroeconomic forces of development that impact business, economy, society, cultures and personal lives²—are changing the face of the industry and setting the course for Automotive 4.0. Automakers and their supply chains are under pressure to meet growing demand in developing and emerging markets and, at the same time, to meet increasingly stringent fuel efficiency and emissions mandates.

11.2 billion
by 2100

Changing demographics

The global population is growing. It is projected to increase by more than 1 billion people—to 8.5 billion in 2030—and to further increase to 9.7 billion in 2050 and 11.2 billion by 2100³, primarily due to growth in developing nations and Africa in particular. In the long term, **skills shortages will become a serious problem in places**, such as Germany, Japan and Eastern Europe, **with decreasing populations**.⁴

The global population is aging. Today, 12% (901 million people) of the world's population is 60 years of age or older, and the global 60-plus population is growing by 3.25% annually.

By 2050, nearly a quarter or more the populations of all major areas of the globe except Africa will be 60 or older. The number of older persons in the world is projected to be 1.4 billion by 2030 and 2.1 billion by 2050, and could rise to 3.2 billion in 2100. **Population aging is projected to have a profound effect on the number of workers per retiree** in various countries.⁵ In parallel, **the aging population adds to the demand for safer vehicles**, including semi-autonomous and autonomous vehicles, building on existing safety features like traction control, stability systems, lane support and automated braking.⁶

¹ Roland Berger Strategy Consultants, *Trend Compendium 2030*, http://www.rolandberger.com/expertise/trend_compendium_2030/

² Singh, Sarwant, *New Mega Trends: Implications for our Future Lives*, (London: Palgrave MacMillan, 2012), 4

³ United Nations Department of Economic and Social Affairs/Population Division, *World Population Prospects: The 2015 Revision, Key Findings and Advance Tables* (New York: United Nations, 2015), 2

⁴ Roland Berger Strategy Consultants, *Trend Compendium 2030* (Munich: Roland Berger Strategy Consultants), 10

⁵ United Nations Department of Economic and Social Affairs/Population Division, *World Population Prospects, The 2015 Revision, Key Findings and Advance Tables* (New York: United Nations, 2015), 7

⁶ Kota Yuzawa, Patrick Archambault, Stefan Burgstaller, Bill Shope, Heather Bellini, *Cars 2025: Vol. 1, A disruptive new era of the Automotive Age*, (New York: Goldman Sachs Global Investment Research, 2015), 8

+25% e-cars by 2025

Urbanization is giving rise to megacities. The world's urban population is set to grow by 50%—to 6 billion people—by 2050⁷, giving rise to a greater number of megacities (population 10 million or more). Of the 10 largest megacities in 2025, only two—Tokyo and New York—will be in mature markets. **As the world's road grow more crowded, increasing traffic heightens people's need for safety.**⁸ **Vehicle use restrictions could become more stringent as urbanization increases**, with regulators looking at a more aggressive “well to wheels” approach to measure the social impact of automobiles across the product life cycle instead of focusing sole on the automobiles.⁹ That approach requires authorities to make an integrated assessment of the costs and effects of extracting, processing and delivering an energy source to automobiles and using that energy source and generating emissions.¹⁰

Globalization and future markets

Globalization is continuing. Defined as the increasing internationalization of markets for goods and services, the means of production, financial systems, competition, corporations, technology and industries¹¹—globalization is nothing new for the automotive industry. Some would even argue that globalization in the industry began with the technology transfer of Ford Motor Company's mass production model to Western Europe and Japan after World Wars I and II, continuing with the US import of fuel-efficient cars from Japan to the US as a result of the oil embargo of 1973-1974.¹²

And the challenges are growing. In the last decade, though, the shift has become more pronounced. Original equipment manufacturers (OEMs) must grapple with new risks—including **demand, supply misalignment, volatile raw material prices, changing regulatory policies and shortages of qualified workers in developed markets.** Naturally, OEMs' and Tier 1 suppliers' belt tightening in response to those risks presents challenges to Tier 2 and Tier 3 suppliers, requiring them to become increasingly strategic.¹³ That can mean **diversifying their risks by creating relationships with a range of OEMs and developing products that can serve customers outside of the industry** ecosystem.

⁷ Ibid., 10

⁸ Continental Corporation, “*Safety megatrend or the vision of accident-free driving*,” October 9, 2015. http://www.continental-corporation.com/www/pressportal_com_en/general/safety/safety_intro_en.html

⁹ Paul Gao, Russell Hensley, and Andreas Zielke, *McKinsey Quarterly*, “A road map to the future for the auto industry.” http://www.mckinsey.com/insights/manufacturing/a_road_map_to_the_future_for_the_auto_industry

¹⁰ Ibid.

¹¹ United Nations, European Commission, International Monetary Fund, Organisation for Economic Co-operation and Development, United Nations Conference on Trade and Development, World Trade Organization, *Manual on Statistics in International Trade and Services* (New York: United Nations, 2002), 182

¹² Business & Economics Research Adviser, “Global Automotive Industry,” Issue 2, Fall 2004, updated March 2014, <http://www.loc.gov/rr/business/BERA/issue2/industry.html>

¹³ Ernst & Young LLP, “Eight megatrends shaping the global light vehicle industry,” 3

-50 kg = -1 g/km CO₂

Climate change

Climate change is a global concern. It has the potential to threaten global food production, lead to catastrophic flooding and aid the spread of pests and diseases once limited to the tropics. Carbon dioxide (CO₂) emissions are an unavoidable result of burning fossil fuels and a major contributor to climate change. The transportation sector is responsible for up to 27%¹⁴ of CO₂ emissions, a major contributor to climate change and major developed nations are mandating vehicle CO₂ reductions by 30 to 40% by 2025.¹⁵

The global automotive supply chain is responding.

It plays a key role in reducing vehicle CO₂ emissions by developing **more fuel efficient vehicles**, driving **endless powertrain advancement, lightweighting** of vehicles, and developing of **new technologies**—including hybrid vehicles (HVs), electric vehicles (EVs), plug-in hybrid electric vehicles (PHEVs), and fuel cell vehicles (FCVs). While electrified vehicles are expected to represent 25% of global car sales by 2025, the conventional gas/diesel engines will remain in the lead—so improvements in ICE technology will be needed to raise the fuel efficiency of HVs and PHEVs. Conventional engine performance will be advanced by innovation around **direct fuel injection, turbo downsizing** and **cylinder management technologies**.¹⁶

On the lightweighting side, a 50 kg drop in vehicle weight cuts CO₂ emission volume by at least 1 gram per kilometer. Automakers have managed to reduce vehicle weight in recent years by, for example, using plastic for fenders and doors, and improved steel alloys for the chassis. Emerging lightweight materials—like high-speed steel for structural parts and carbon fiber for structural parts like frames, hoods and tailgates that require high strength—offer distinct weight advantages, but their costs often have prohibited their use.¹⁷

Technology and innovation

The pace of innovation is escalating. Continuous innovation and access to technologies that support innovation are essential all along the mobility value chain, as **automakers and their supply partners race to meet societal, economic and environmental challenges**. New technologies are impacting technology diffusion across the globe and creating new growth opportunities—especially in developing countries—and setting the next stage for globalization.¹⁸

Innovation is driving prosperity and, at the same time, the world is going digital. **Technology is providing new inroads to meeting increasing demands for energy and transportation and dealing with environmental challenges**, as well as **meeting consumers' demands for convenience, connectedness and safety**—and giving rise to **autonomous driving, increasingly connected vehicles, and ever-greater automotive complexity**.

Technology will drive **innovation all along the powertrain—turbocharger, transmission, diesel injection and electromobility**—as well as **safer braking systems**, more reliable **airbags**, and the **ball bearings** found throughout light vehicles. Collaboration among stakeholders, including with reliable, innovative supply partners who can meet or exceed the industry's need for timely, on-target, zero-defect manufacturing solutions, will be essential to automakers' ability to keep pace with growing product demands and seize new opportunities in a changing global landscape.

¹⁴ United States Environmental Protection Agency, "Sources of Greenhouse Gas Emissions," <http://www3.epa.gov/climatechange/ghgemissions/sources.html>

¹⁵ Kota Yuzawa, Patrick Archambault, Stefan Burgstaller, Bill Shope, Heather Bellini, *Cars 2025: Vol. 1, A disruptive new era of the Automotive Age*, (New York: Goldman Sachs Global Investment Research, 2015), 6

¹⁶ Ibid., 16

¹⁷ McKinsey & Company, *Lightweight, heavy impact: How carbon fiber and other lightweight materials will develop across industries and specifically in automotive*, 2012, 9-10

¹⁸ Roland Berger Strategy Consultants, *Trend Compendium 2030*, http://www.rolandberger.com/expertise/trend_compendium_2030/

We keep you turning

Cars are objects of desire for some, and for others, simply a way to get from point A to point B, but they are essential to all. More so than for other industries, quality, safety and economic viability are of particular importance to the automotive industry; this key market poses numerous challenges to any machine tool manufacturer. Tornos has specialized in this field for over 50 years, working closely with manufacturers (OEMs) and Tier 1 and Tier 2 integrators to meet ever-stricter standards and the needs of consumers.

With our vast experience throughout the vehicle production chain, our holistic approach, our complete production program and our global presence, we are the perfect partner to automotive manufacturers and suppliers.

Moreover, thanks to our experience across a broad range of industry segments, Tornos is uniquely positioned to partner with manufacturers, offering them support in new technologies relating to hybrid engines, for example.

Tornos offers you professional, specialist solutions in this very demanding field. To meet the needs of the automotive industry, major technical advances are required. Relying on our technology, our quality and our experience in the automotive field is the key to success.

We invite you to discover our solutions by contacting us or by simply visiting our website.

Ever increasing demands for uncompromising precision, complexity and quality at the best price put great pressure on supply chain partners. Tornos guarantees the latest technology in terms of precision and performance to meet those requirements.



Electromobility and electromechanics

IMPROVEMENTS IN ICE TECHNOLOGY WILL BE NEEDED TO RAISE THE FUEL EFFICIENCY OF HYBRID VEHICLES AND PLUG-IN HYBRID ELECTRICAL VEHICLES.

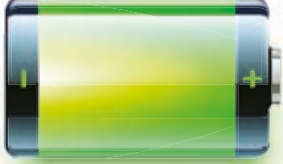

The future will certainly belong to electromobility. Until then, researchers and developers at leading automobile manufacturers and suppliers must overcome a large number of technological challenges.

Electromobility also calls for completely new solutions in the field of automotive electronics. Power electronics plays a key role in this context. In hybrid vehicles, the shoebox-size component handles the energy management between battery, electric motor, and ICE. Power electronics is high technology—and poses major challenges for research and production.





Hybrid

Hybrid vehicles are an increasingly common sight on the roads today. The hybrid represents an important technological bridge to the all-electric drive.

Hybrid combines an ICE with an electric motor. The electric motor relieves the strain on the ICE, particularly in situations requiring high power, for example when driving off and accelerating, and can reduce fuel consumption and CO₂ emissions by more than 20%

One variation of the hybrid system is the PHEV. In terms of construction, it is similar to the other designs, but it can be charged from any household socket, and features a battery with greater capacity. This increases the distance that can be driven using only electricity.

Electrical powertrain

Energy-efficient ICEs will continue to play an important role for medium- and long-distance travel. On the other hand, hybrid drives, featuring a combination of an ICE and an electric motor, are suitable for both driving profiles. In the long term, the electric motor will become the most important automotive powertrain, but the ICE will dominate until then and transition will take time.

While much remains unclear as technologies evolve, one thing is certain: With our experience in the connector business, Tornos will be there for you. We have helped to shape all kinds of connectors, from Formula 1 cars and manned and unmanned aircraft to satellite and many more connector uses.

In the electronic connector industry, swap ratio—size, weight and power output of connectors—is a critical factor as the industry continually evolves. Our customers must continuously push the boundaries and produce ever-smaller connectors and we are there to help them. One example is our sliding head lathes with 2 mm copper alloy bar that is turned to produce male and female connector pins with diameters of 1mm down to 0.3mm. As industry evolves, these dimensions may get even smaller.

Electric powertrains will become more and more affordable and we will be there to help you convert our machines.

Supercharging your automotive production

ORIGINALLY PROVEN ON THE RACETRACK NEARLY HALF A CENTURY AGO, TURBOCHARGERS ARE ENJOYING A COMEBACK IN CONSUMER AUTOMOBILES DUE TO DEMAND FOR GREATER FUEL EFFICIENCY WITHOUT SACRIFICING POWER OR PERFORMANCE.

WE PROVIDE THE PRECISION KEY TO MANUFACTURING ESSENTIAL TURBOCHARGER COMPONENTS MADE OF DIFFICULT-TO-MACHINE MATERIALS.

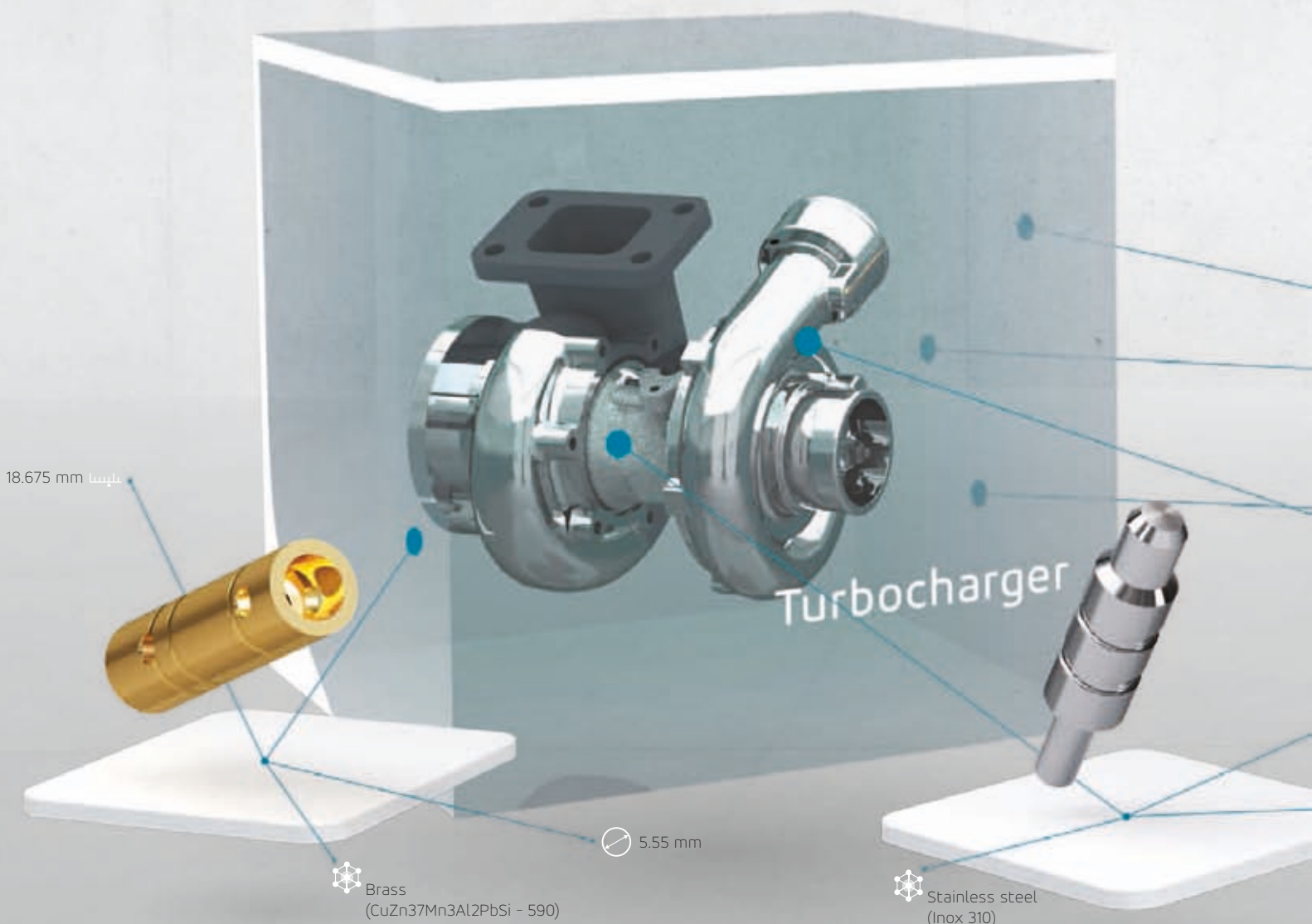

Reducing fuel consumption and CO₂ emissions and maintaining performance are the challenges that automotive engine manufacturers face today. A turbocharger is a turbine-driven device that increases the engine power by changing the oxygen ratio in the cylinders to improve combustion. The complex nature of the systems requires manufacturing precision to enable maximized efficiency and torque to compensate for the downsizing of the engine.

The material on the hot side of the component is exposed to temperatures around 1000° C. This requires very strong and abrasive material such as austenitic stainless steel. Machining of the abrasive material is often characterized by short tool life, uneven wear and difficulties meeting the workpiece tolerances especially when it comes to turned parts.



We help you deliver safe, sophisticated stopping power.

WITH GLOBAL CAR OWNERSHIP SOARING, ESPECIALLY IN DEVELOPED NATIONS, ACTIVE SAFETY SYSTEMS CONTINUE TO PLAY AN ESSENTIAL ROLE IN COLLISION PREVENTION.

AUTOMAKERS AND THEIR SUPPLY PARTNERS CONSISTENTLY TURN TO US FOR HIGHLY RELIABLE TURNING TECHNOLOGIES NECESSARY FOR PRECISELY MACHINING BRAKING SYSTEM COMPONENTS.



The braking system, a key safety element, has become more and more sophisticated, incorporating various anti-slip systems like anti-lock breaking systems (ABS), traction control systems (TCS), kinetic energy recovery systems (KERS), electrical hand brakes and integrated braking systems. In addition to these technological challenges, braking systems today must be lighter to consume less fuel and curb CO₂ emissions.



Steering you toward success.

WHETHER THEY'RE DRIVING A SUB-COMPACT CAR OR A LUXURY SEDAN, PRECISE, DYNAMIC STEERING IS A MUST-HAVE FOR DRIVERS.

WE PUT STEERING SYSTEM COMPONENT MANUFACTURERS ON THE RIGHT COURSE FOR THE FUTURE WITH TURNING TECHNOLOGIES, APPLICATION-SPECIFIC SOLUTIONS AND A WIDE RANGE OF CUSTOMER SERVICES.

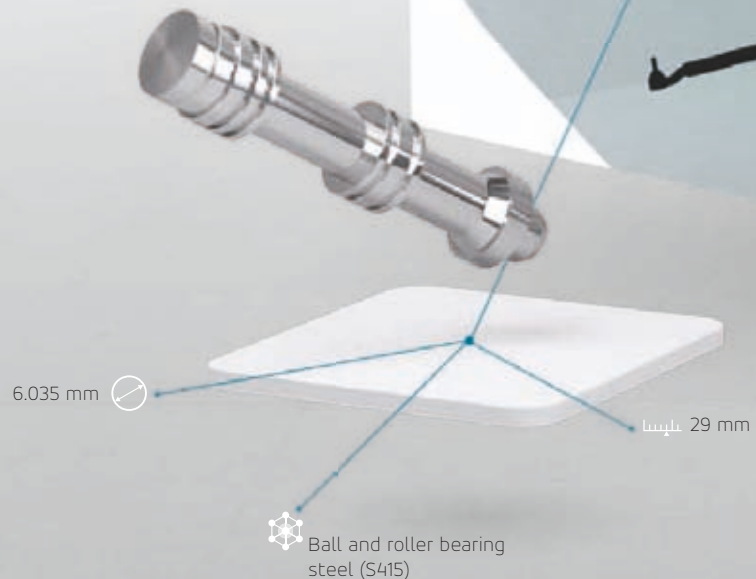

Hydraulic regulator, shaft and pinion hydraulic steering remains a major steering solution for today's vehicles. Major components, aside from the rack and pinion, include valve assembly, rack tube housing, yoke plug, flexible bellows and pressure lines.

Originally designed for the small-car segment, electrical power systems have evolved into a family of modular and scalable solutions supporting all car types. One of the major benefits of the column drive system is its clever packaging. Electrical steering system technology delivers a cost-effective and fuel-efficient steering solution while being fully capable meeting five-star European New Car Assessment Program (NCAP) crash requirements, providing leading-class steering dynamics and intelligent actuation for the fast-growing field of driver assistance systems (DAS) and autonomous driving.

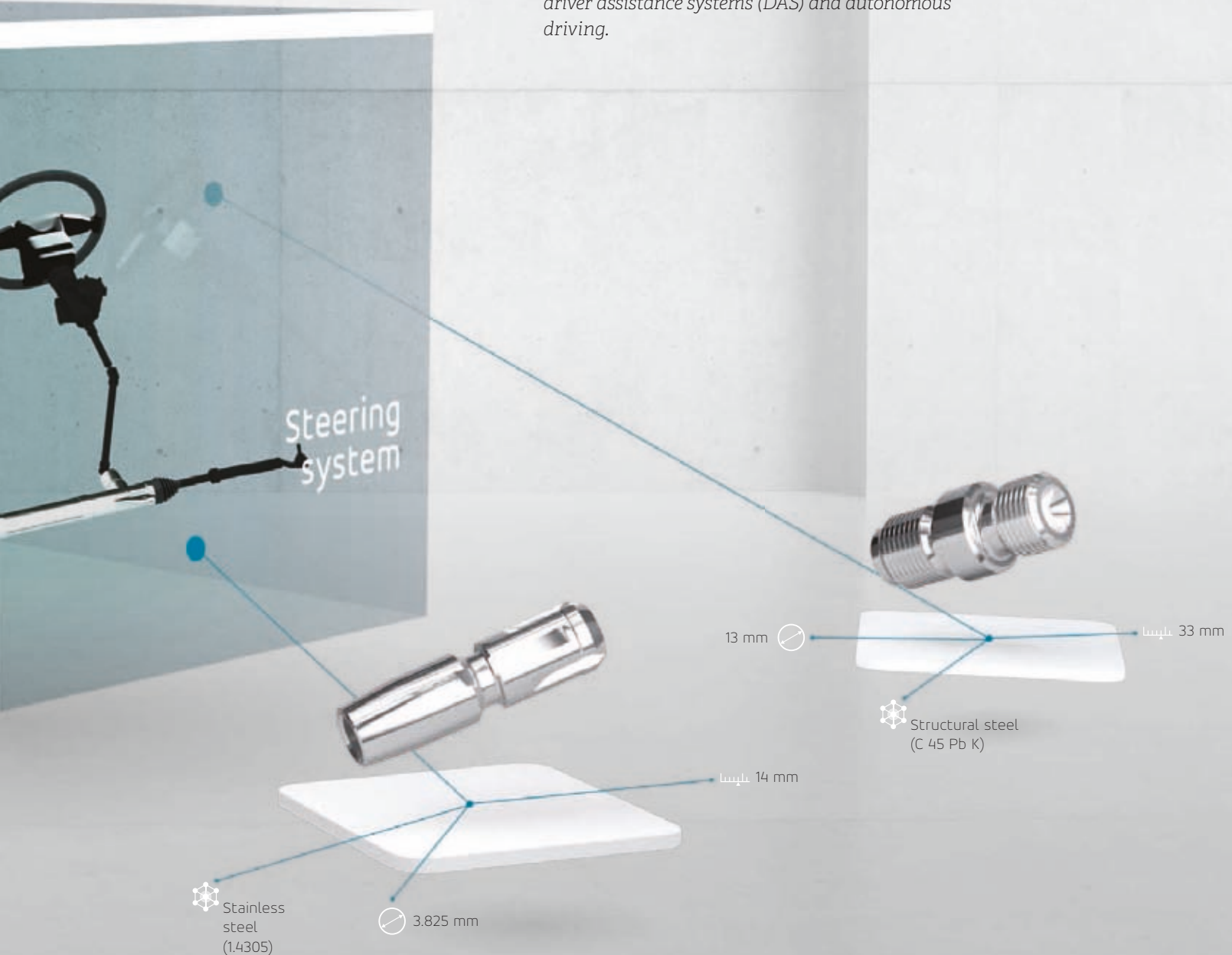

Facing the road ahead with confidence we are at your side.

OCCUPANT PROTECTION TECHNOLOGIES ARE NOTHING NEW, BUT THEY HAVE EVOLVED TO BECOME A KEY AUTOMOBILE SAFETY FEATURE.

AIRBAG SYSTEM MANUFACTURERS PUT THEIR TRUST IN US FOR THE TURNING SOLUTIONS, EXPERTISE AND SUPPORT ESSENTIAL TO THEIR PRODUCTIVITY AND PRECISION.

Airbags and Inflators have evolved significantly since airbag systems were introduced more than 30 years ago. Performance enhancements, new types of gas generation systems and the wide variety of ways these inflators can be packaged within vehicles are all challenges. Dual stage inflators, hybrid inflators, and side, roof and knee airbags are just a few of the ways this important safety feature has developed in recent years.

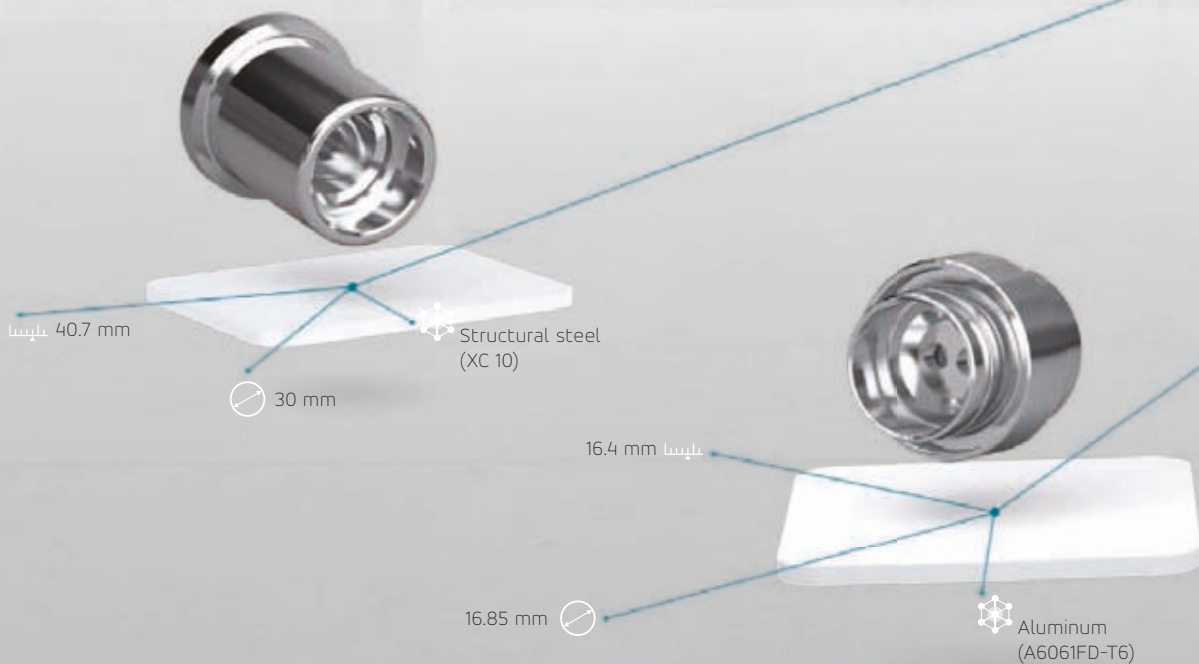

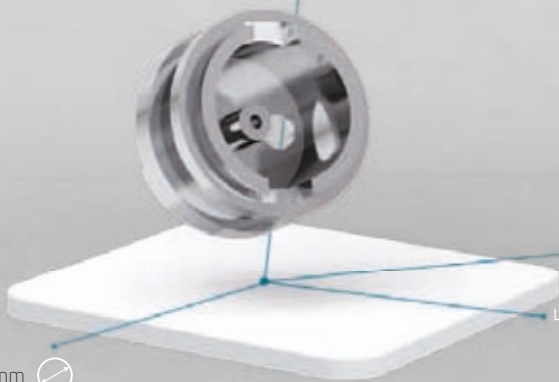
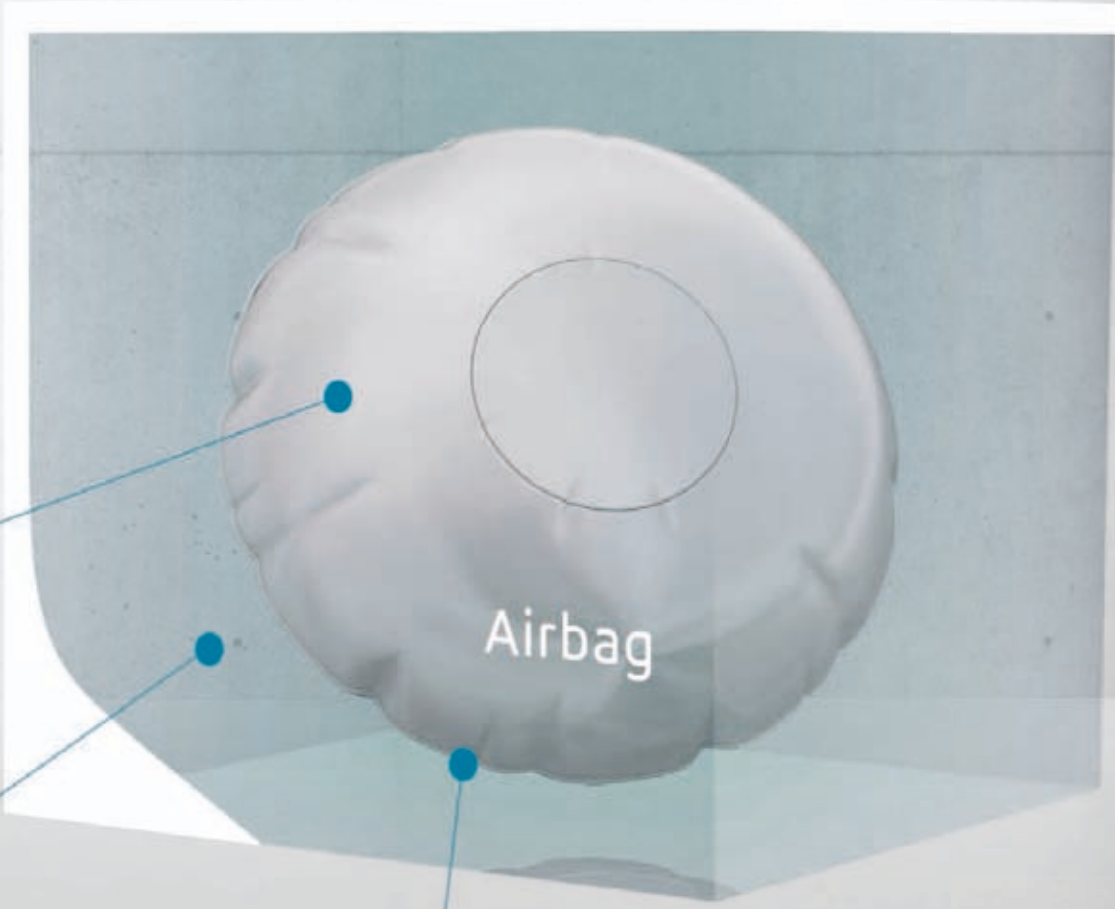

Aluminum
(BS 1474 Grade 2014A)

11.375 mm

19.35 mm

We meet our customers' challenges with a legacy of automotive expertise.

Your challenges

To reduce costs, the car industry is reducing the number of suppliers every year and increasingly collaborating with its chosen suppliers to achieve performance targets. A supplier like you is a specialist, benefiting from the latest know-how. In your capacity as a supplier to the car industry, your challenges include:

- Getting your foot in the door in the first place by conquering the demanding production part approval process (PPAP)
- Consistent quality and in-time delivery
- Controlled process and flow from raw material to final product
- Versatility of orders and part upgrades
- Ever growing price pressure
- Very demanding requirements in terms of quality, tolerance and statistical inspection levels
- Reactivity: Large batches are broken down in small lots according to demand, with very short deliveries.

Your ability to guarantee compliance with these parameters is one of your best means of success.

Our experience

With some 50 years of close partnership with automakers and OEMs worldwide, Tornos provides tools and in-depth application know-how for most components in all sizes of automotive vehicles, from motorcycles to trucks. With a strong foothold in R&D and close cooperation with both customers and tool manufacturers, we have the most complete offer in our industry when it comes to Swiss-type turning or multispindle solutions.

The automotive industry is characterized by high volume production in purpose-built manufacturing plants with a high degree of optimization and automation. Quality component control and on time delivery at the better price are the main focus on this industry.

As the industry becomes more and more advanced, the demand for rapid R&D increases. New materials require new tools and innovative ways of working with applications. However, the more advanced manufacturing becomes, the harder it



is for the individual companies to keep all skills in-house. This opens up new partnerships and cooperation between manufacturers, toolmakers, machine makers, universities and research centers—and this opens doors to innovation and knowledge exchange throughout the industry.

Engines today are under heavy development due to a need for reduction in emissions and increased fuel efficiency. The results are a need to downsize engines, improve in efficiency, and search for alternatives to the ICE—all of which require heavy R&D investments.

Hybrid and electrical vehicles as well as smart vehicles require more electronics and connectors. With our vast experience with these applications, Tornos is uniquely able to share valuable experience with customers.

*The more challenges
you overcome, the greater
your success.*

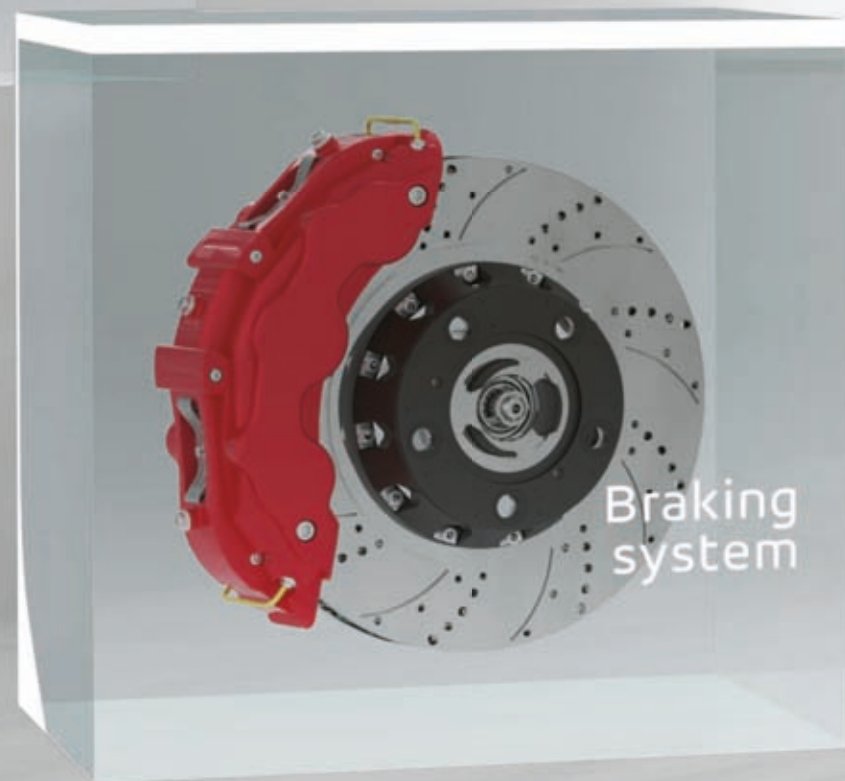
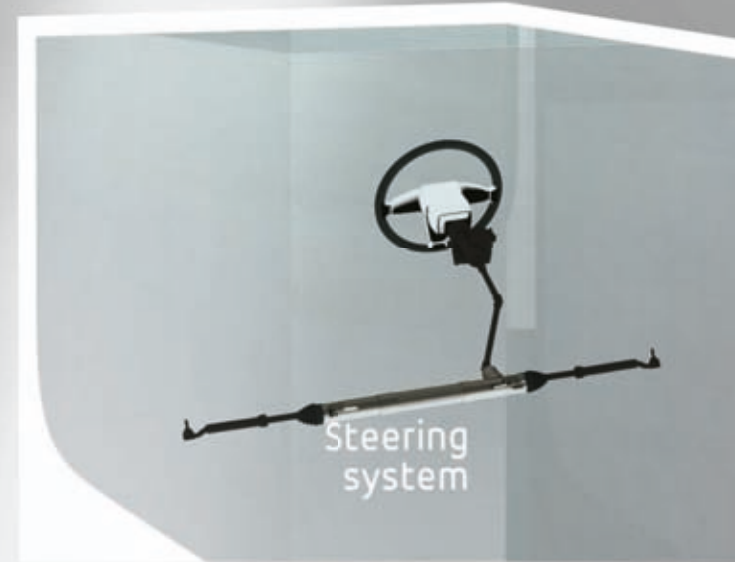

Achieving high productivity is a challenge, with many hurdles to overcome, including reducing cost-per-part, improving process security, shortening cycle times and securing component quality.

With our competitive solutions for reliable, low-cost manufacturing, backed up with in-depth application know-how, Tornos is uniquely positioned to drive your success across a broad range of essential automotive manufacturing applications.



Injector



Transmission

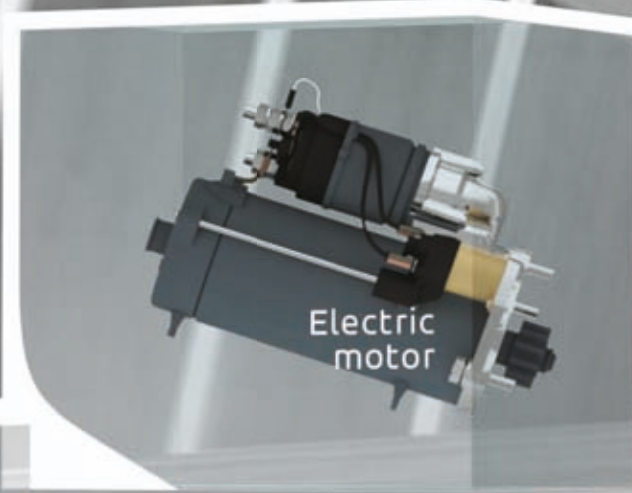

Electric motor



Ball bearing

Maintaining the optimal pressure in your production

SUPERIOR INJECTION REDUCES FUEL DROPLETS AND IMPROVES ENGINE EFFICIENCY. OUR HIGH-PRECISION SOLUTIONS INJECT SUCCESS INTO YOUR MANUFACTURING PROCESSES.

Diesel parts

Nozzle and plugs are critical for an engine. The pre-heat, starting and post-glow phases of a glow plug's operation affect not only the start-up function, but the vehicle's overall performance as well. Nozzles need to withstand the heavy demands of today's diesel engines. Each nozzle is engineered for exact precision and durability, requiring the best machining capability.

Gasoline parts

In gasoline engines, the spark plug ignites the air-fuel mixture in the engine cylinder with a high-energy spark. The necessary high voltage is produced by the ignition coil, which transforms electrical energy from the battery and provides the high voltage to the spark plug at the ignition point. For sustained performance, spark plug elements need high strength, high precision and constant quality.

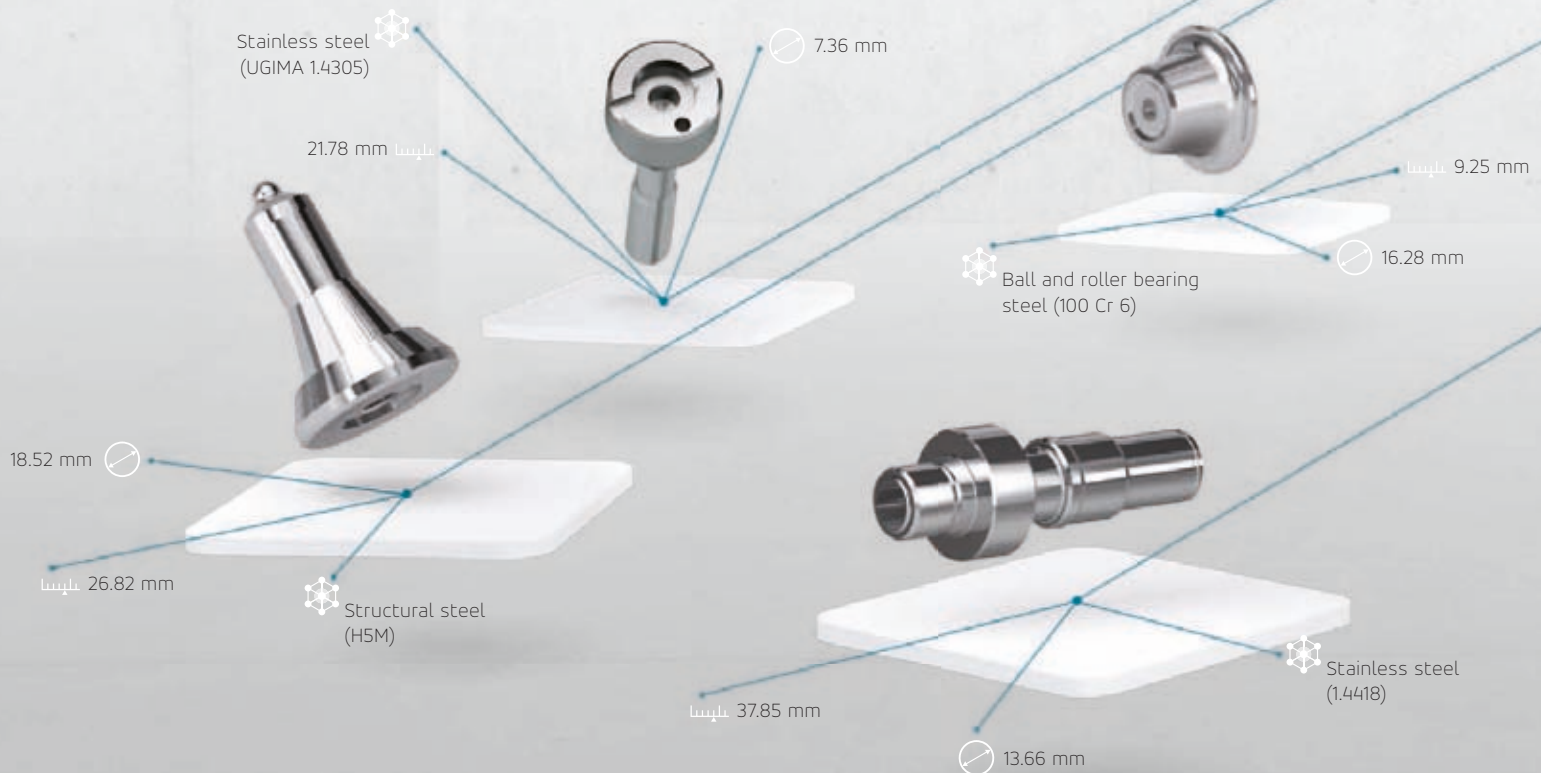

Material

Diameter (in mm)

Length (in mm)

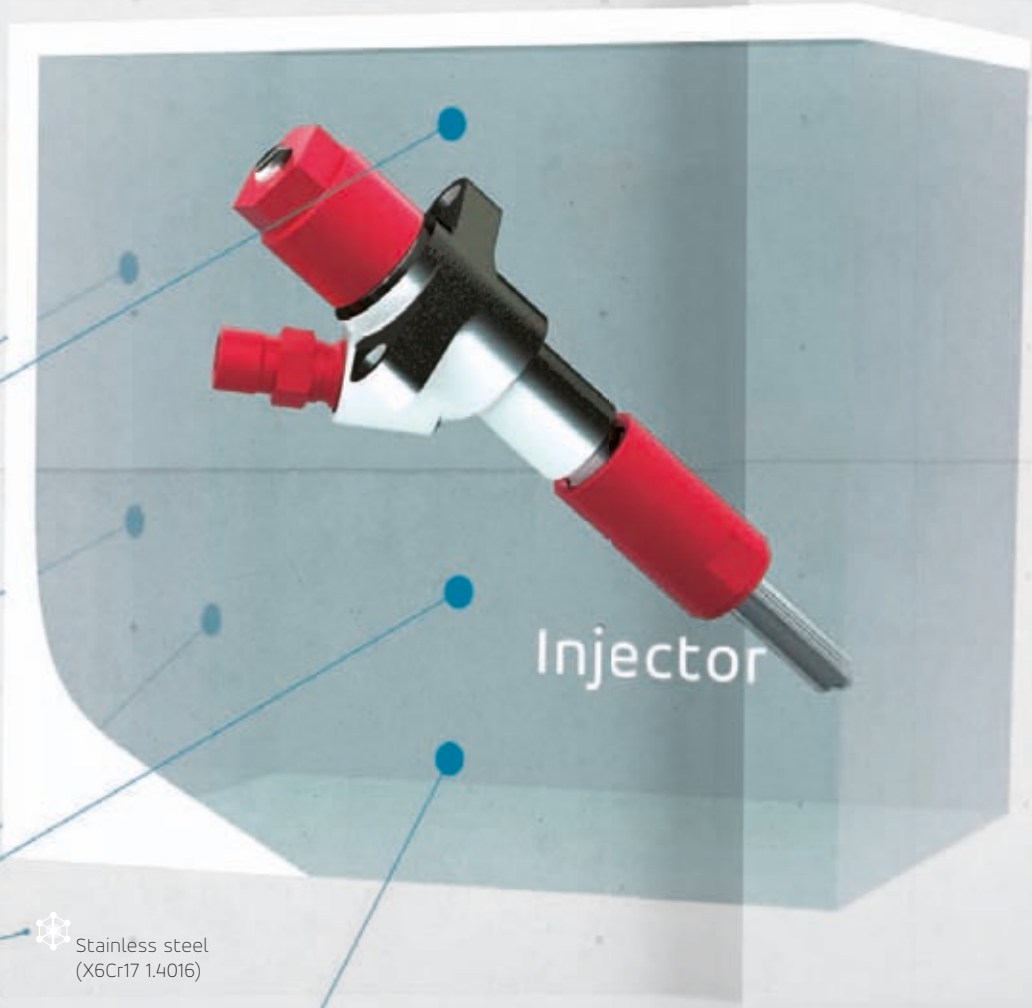

Injector



Stainless steel
(X6Cr17 1.4016)

6.1 mm

8.455 mm



94.7 mm

Stainless steel
(1.4305)

14.3 mm

Multiplying your productivity

ADDING GEARS ALLOWS A CAR'S ENGINE TO OPERATE AT A MORE EFFICIENT SPEED, MORE FREQUENTLY. CONTEMPORARY TRANSMISSION TECHNOLOGY OFFERS MORE GEARING OPTIONS TO RAMP UP VEHICLE FUEL EFFICIENCY.

BY THE SAME TOKEN, OUR SOLUTIONS ARE GEARED TO ACCELERATE OUR CUSTOMERS' EFFICIENCY—TODAY, TOMORROW, AND BEYOND.

Tornos has long experience with all kinds of transmissions: automated step transmissions (AT), continuously variable transmissions (CVT), double clutch transmissions (DCT), as well as automated manual transmissions (AMT).

The new double clutch transmission requires small, high-precision parts. As a longtime, expert partner to the Swiss watchmaking industry, Tornos has proven itself as a supplier of lathes handling this highly precise work.

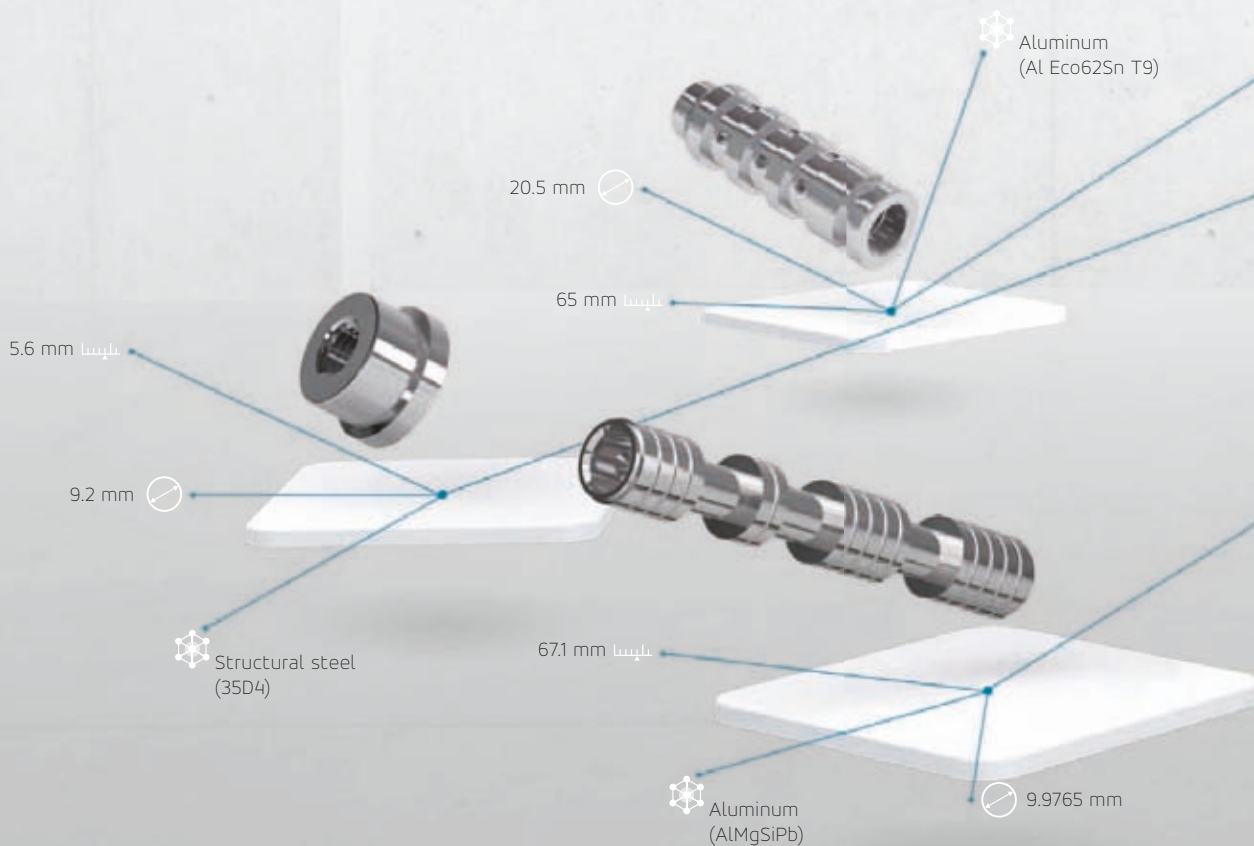

Material

Diameter (in mm)

Length (in mm)

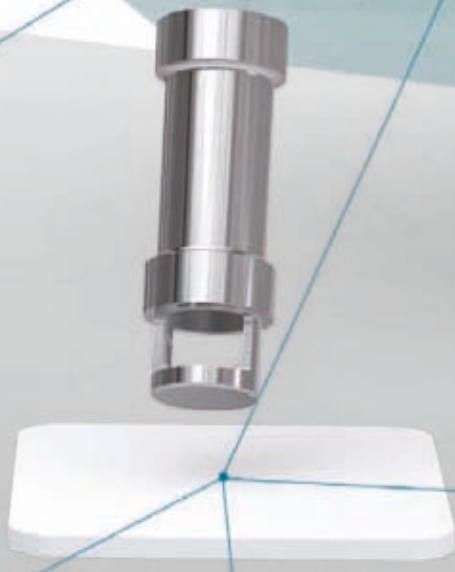
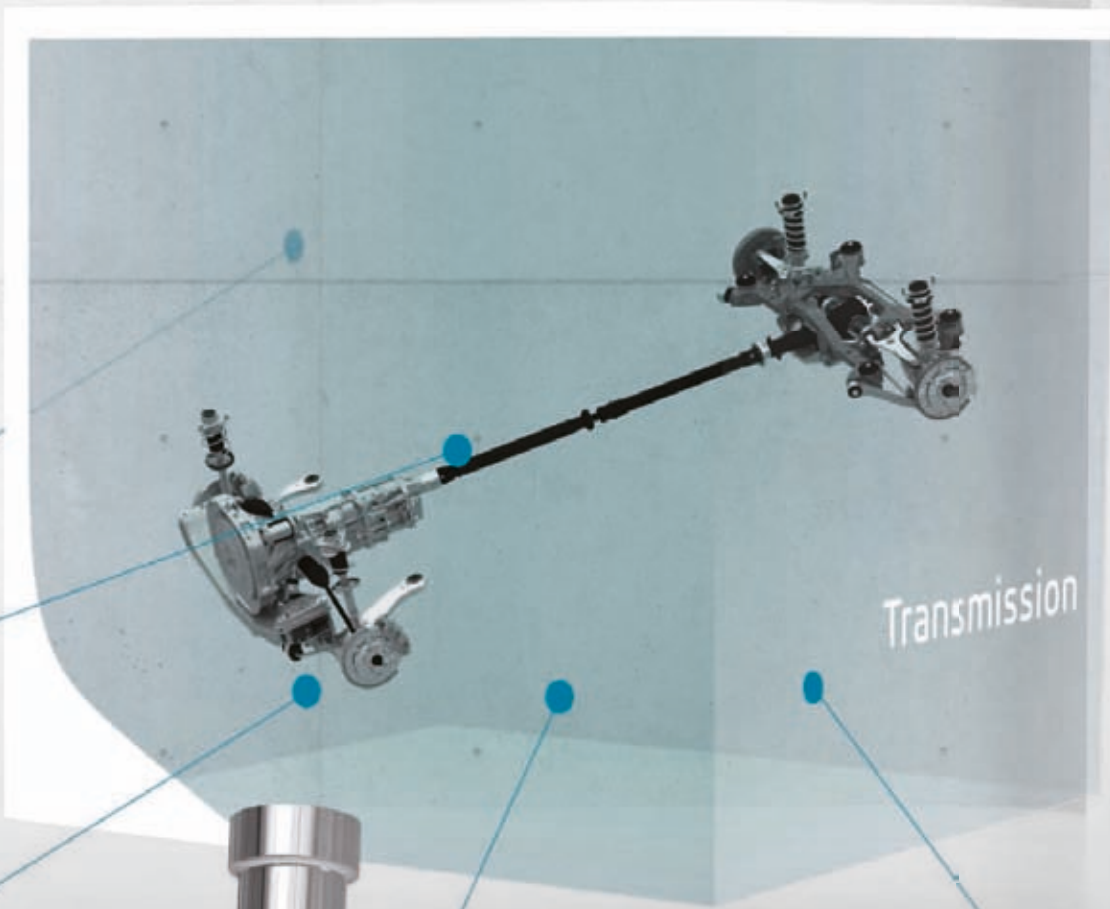

33.45 mm

Aluminum
(6082-T6)

11.4 mm

36.21 mm



Free cutting
steel
(70 SPb 20)

7.11 mm

Empowering your manufacturing performance.

FROM THE SIMPLEST TO THE MOST COMPLEX ELECTRIC MOTORS, WE EMPOWER OUR CUSTOMERS' MANUFACTURING PERFORMANCE.

AT THE DAWN OF THE MODERN AUTOMOTIVE ERA 130 YEARS AGO, CARS HAD JUST ONE MOTOR. TODAY'S VEHICLES ARE JAM PACKED WITH ELECTRIC MOTORS SERVING A WIDE VARIETY OF PURPOSES.

OUR SOLUTIONS ENERGIZE OUR CUSTOMERS' TURNING PROCESSES AND PERFORMANCE.

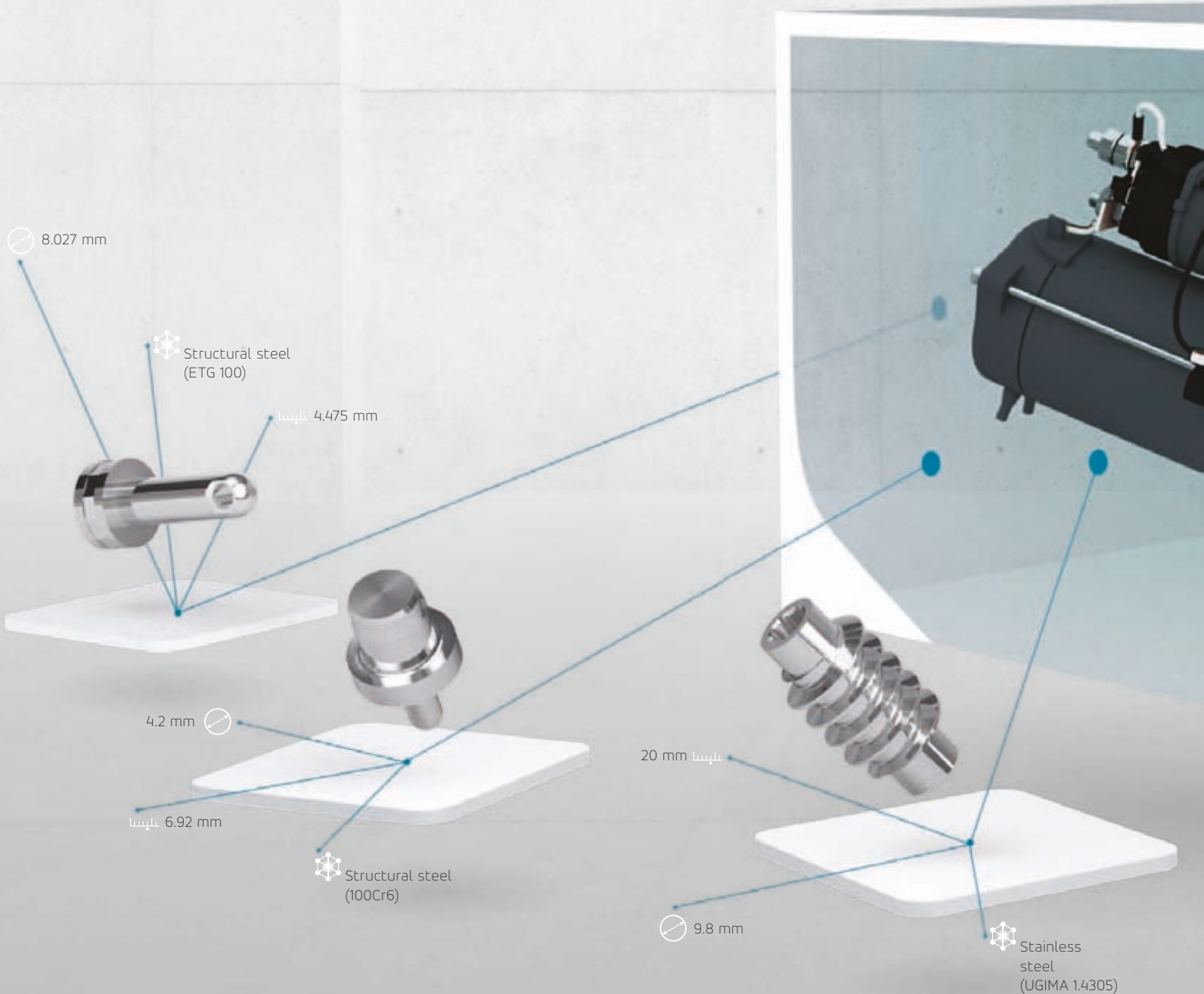

Electric motors are widespread in today's automotive sector, from basic solutions for convenience functions and basic vehicle equipment, to components and systems for engine thermal management, air conditioning, and windshield cleaning, and electric seat and tailgates.

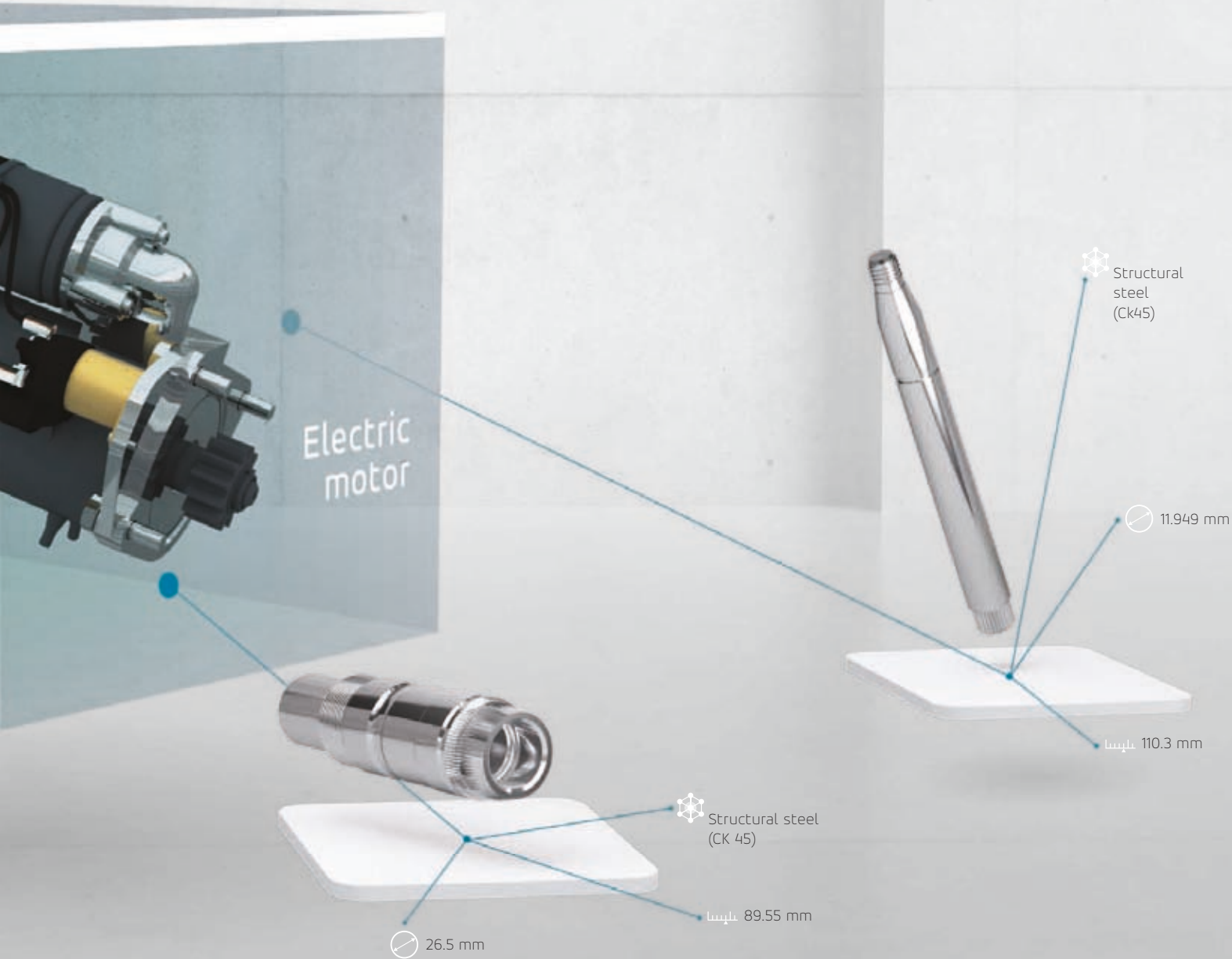

*Across a broad spectrum of applications,
perfectly precise turning is in our DNA.*

JUST AS CONSUMERS DEMAND THE SMOOTH, SEAMLESS ACTION ENSURED BY THE BALL BEARINGS THROUGHOUT THEIR VEHICLES, OUR CUSTOMERS EXPECT THE SAME SEAMLESS PERFORMANCE FROM OUR TURNING SOLUTIONS.

WE DELIVER THE TECHNOLOGIES AND SUPPORT ESSENTIAL TO OUR CUSTOMERS' CONSISTENT PRODUCTIVITY.

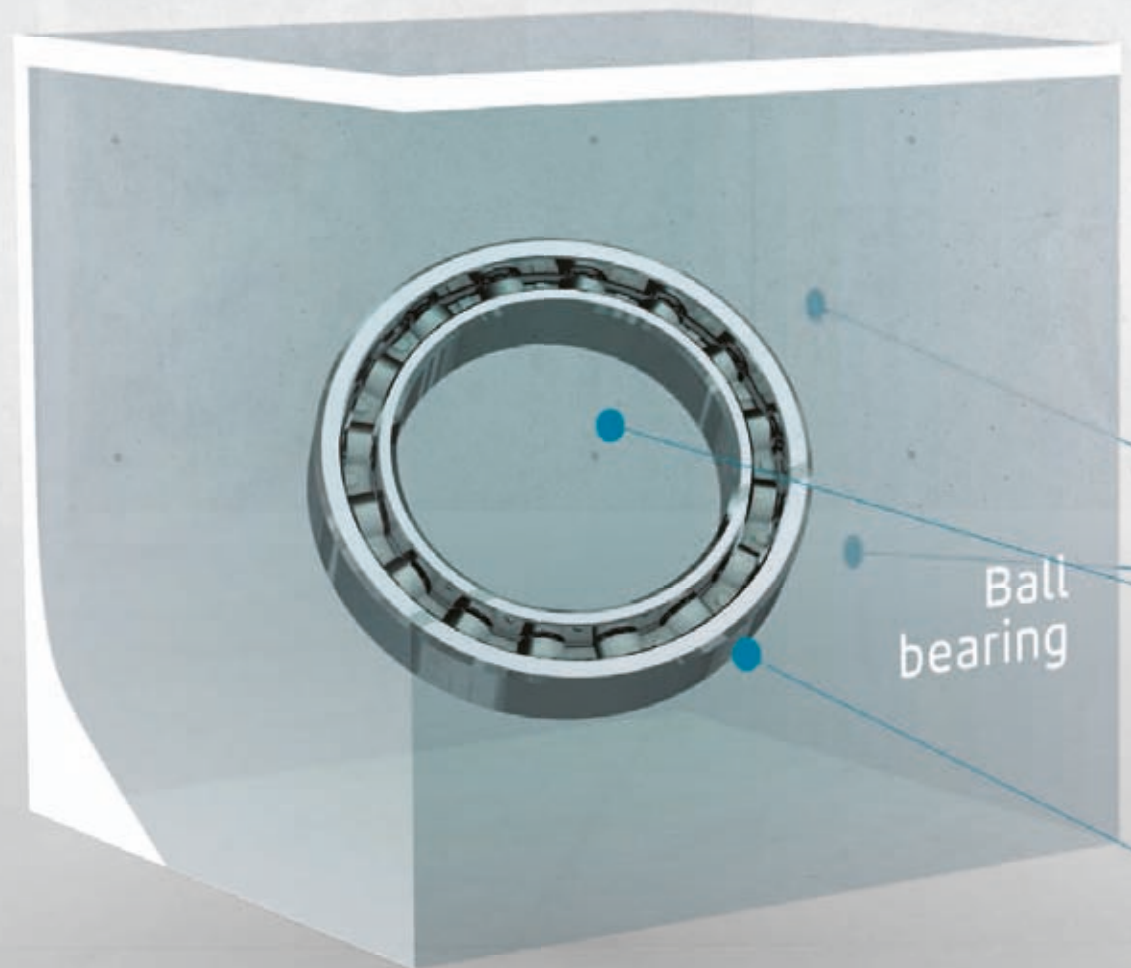

Ball bearings are at the heart of the movement of the cars. They are found not only in the wheels, but also literally everywhere: in the electrical and security systems (such as headlights and comfort systems like climate control and electric seats). Ball bearings represent the foundation of automotive manufacturing: Without their ability to reduce the drag, a vehicle would not move.

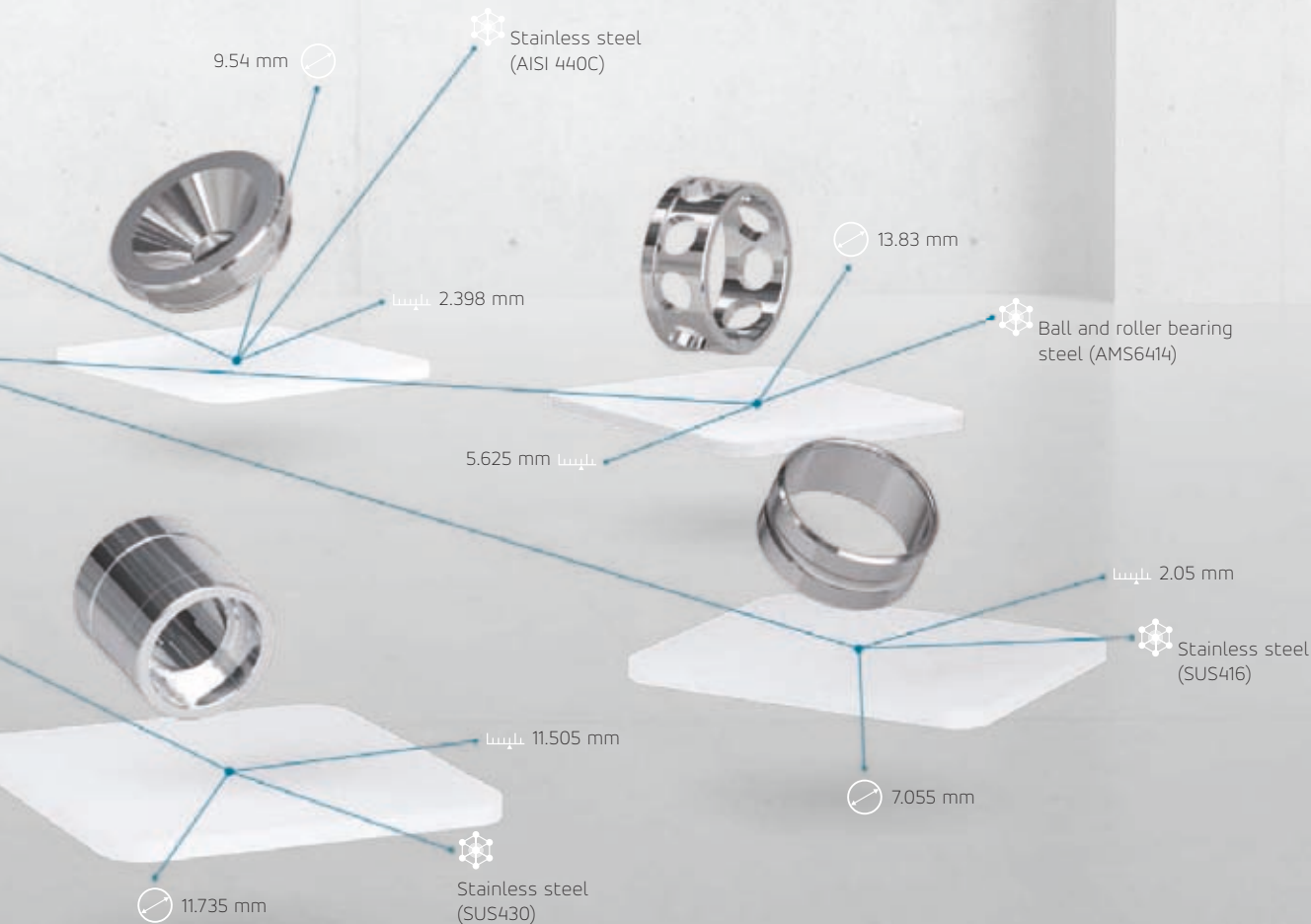

With a solution for every challenge, we secure our customers' application success, operational uptime, quality, and efficiency.



Solution: high-pressure coolant

Increasing the coolant pressure has a positive effect on both chip breaking and tool life. Tornos high-end machines designed for high productivity have a tool holder with fixed nozzles to enable high precision of the coolant supply at the cutting edge of the insert, a direct route to excellent chip breaking, process security and high productivity. Coolant delivery optimizes the machine capabilities and further improves tool life and chip formation. Since early 2000, machine builders have increased the pressure and flow on their machines each year, resulting in increased electrical power consumption. With our latest product, Tornos has

defeated this dilemma with built-in coolant that increases precision in the oil jet to reduce the flow and, consequently, reduce energy consumption of the machine while achieving the same highly precise results.

The coolant jet has four main effects:

- *To cool the insert in the contact zone*
- *To quickly force the chip away from the insert face, reducing wear on the insert*
- *To help break the chip into smaller pieces and evacuate it from the cutting area*
- *For rough turning, a coolant pressure of 80 bars provides a longer tool life than with a regular pressure*

Tool life—times seven

By applying a coolant pressure of 80 bars, tool life increases by seven times in the finishing operation. The wear value (VB) is lower after 33 minutes in cut with 80 bar pressure, than after less than five minutes with a conventional coolant pressure of 15 bar. For the roughing operations, tool life increased by approximately 40% when using high-pressure coolant.

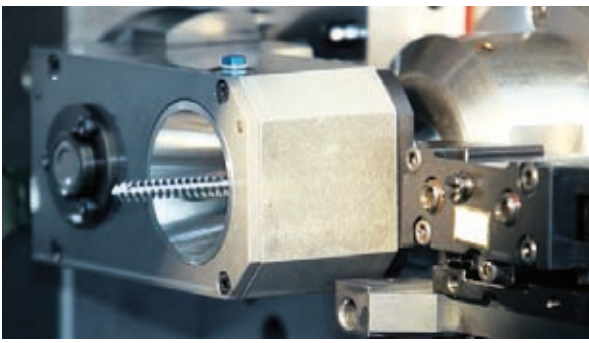

Solution: thread whirling

When it comes to machining worm screws for electrical motors, Tornos' unique thread whirling expertise—acquired as a go-to partner to medtech manufacturers—is a strong asset. We are the only company offering this process on multispindle and single-spindle lathes.



Solution: additional handling

Parts machined on an automatic turning machine are often extracted by free fall. Trends—especially within the automotive industry—are toward monitored parts and palletization of parts. Here, parts are gripped by a collet that transfers them to a pallet system. For continuous production, the capacity of such a system merely depends on the type of installation. One variant is the use of a robot to load stamped workpieces and unload machined parts. This kind of automated model does not complicate things for the operator; even the programming can be carried out in standard mode.

Advantages of automatic loading:

1. Reduced cost due to less part handling
2. Reduced part damage due to controlled part unloading
3. Reduced throughput time from production to delivery
4. Consistent quality, uncompromised by human factors



Solution: faultless quality

It is no longer conceivable for cars to break down. Consumers expect nothing less than the highest levels of quality and vehicle safety—and those expectations could well be described as absolutely standard. The automotive industry now requests a level of quality of five or fewer defective parts per million. To ensure this level of quality, Tornos partners with specialists in controlling and measuring procedures and has developed an interface that is able to communicate with various types of measuring systems. Data from this interface is made available to suppliers of these systems who then adapt them. This partnership guarantees total compatibility between the machine and the measuring system for the operator who, as a result, has one less major issue. This interface is available on single- as well as multispindle machines and allows corrective data to be transmitted. If the measuring system detects a gradual drift from input data—due to tool wear, for example—a corrective measure is automatically triggered by the turning machine's control unit. In this way, the operator can monitor both tool wear parameters and any sudden shift from an input dimension resulting from tool failure, because in this case the system automatically actuates an alarm and can stop the machine.

We also offer various systems to monitor the torque of the motor spindle or motor axis for abnormalities such as tool wear or breakage.

The system's advantages include:

1. Reduced tooling costs due to extended tool lifetime.
2. Increased machine efficiency due to reduce machine stops for tool changes
3. Reduced parts scrap due stopping the machine due to tool breakage

Finishing a part on a single machine is a benefit much appreciated by the automotive industry. When issues arise, locating the cause is much simplified and the quality of the parts increases because machining conditions remain unchanged for the whole batch.



Solution: chip management

Depending on the volume and the material to be machined, swarf extraction is a process that can cause the most problems, especially if the operator requires automated production that includes minimum monitoring.

To overcome this, we advise removing swarf using high-pressure pumps (35, 80 bars). Additional assistance is available for the operator in the form of a universal swarf conveyor that handles several types of swarf from brass and aluminum to stainless steel.

An important factor in chip management is the way the oil is filtered. Clean oil is necessary to use high-pressure pump and increase tool life and quality of machining. In addition, the life of the pump's chiller and other peripherals in the loop is increased.

We constantly filter our oil; when a filter is dirty, we automatically clean it without interrupting the machining process.

On our single-spindle solution, we offer a fluid manager aggregate that concentrates filtering, high-pressure pumps and thermal stabilization in one single unit specifically developed and fine tuned to serve our customers.

On the peripherals and equipment side, Tornos builds partnerships on the basis of its extensive experience.

Solution: chucker

The requirements in terms of chuckers are continuously evolving. Both profiles and dimensions are changing. To ensure maximum flexibility, a robot fitted in place of the slide in position 1 now offers easier loading for different types of parts, allowing angular positioning of the parts.

An additional advantage of using a robot is the ability to unload parts in a controlled way, as far as the machining time will allow. The "robotic loading" chucker concept can be adapted for use with the entire range of machines.

Solution: painless programming

Our multispindle solutions are turning machines with every work position equipped with its own spindle. Does the programming start to become highly complex? A turning machine equipped with more machining options logically requires programming to match the machine's capacities. As each of the multispindle work stations is equipped with its own drive system, its programming is done by station. This facilitates the programming of the turning machine, which becomes as straightforward to program as a three-axis single-spindle machine.

First of all, you could be forgiven for thinking that programming machines of more than 30 axes must be complicated. However, thanks to the programming TISIS concept and to Tornos' multispindle kinematics, the user only programs three axes six or eight times, which is a lot more straightforward. The fact that each work station is equipped with its own powered spindle means optimum machining processes can be carried out at this station without worrying about the others. Managing the turning machine is therefore simplified. Operators enjoy increased flexibility in the programming of their parts. Thanks to independent speeds, they can select a wider range of tools as well as the perfect speed. The operator's expertise is very useful and in workshops equipped with both single- and multispindle turning machines, operators will always be within the same programming family.

Programming intelligence

In today's competitive global marketplace, there's not a moment to waste in meeting customers' demands. Our available TISIS communication and programming software puts you on the fast track to truly effortless programming and real-time process monitoring. TISIS knows your Tornos machine fleet and can help you decide which machine to use for a specific part—but that's not all. It enables you to assess each machine's options, reduces the risk of collisions and resulting stoppages, and improves your productivity and efficiency.

TISIS is a smart and advanced ISO code editor that does the thinking for you. It knows your Tornos



machine inventory, can help you write your code, and points out any coding errors. It puts the code in color and can display your program in an attractive, readable Gantt diagram, making it easy for you to see the critical path and react quickly to optimize the process.

At the same time, TISIS is Industry 4.0 ready and takes the complexity out of process monitoring. Even from a remote location, you can keep an eye on the details of the machining process from your smartphone or tablet. The software also allows you to quickly transfer your programs by USB key or directly onto the machine. Your parts designs in various stages of completion can be stored with your program and your parts are easily retrieved from the database.



Discover the
TISIS video

Tornos Service

Backed by both geographical proximity to customers and a keen understanding of their processes, applications and market challenges, Tornos Service delivers an unparalleled continuum of support: start-up assistance; expert training and coaching; free hotline; on-site operations support and preventive maintenance; original spare parts seamlessly delivered worldwide; complete overhauls to extend the longevity of Tornos machines; and a range of operations and upgrades to expand your application capabilities and profitability.

Buying a Tornos machine is much more than a business transaction. It is your investment in the future. Tornos Service thrives worldwide on securing the predictably high production capability of products carrying the Tornos name.

Situated close to you, as demonstrated by the 14 Tornos Service Centers strategically located across Europe, Asia, and the Americas, we offer a full continuum of authoritative support for you and your Tornos machines, and encompasses the innovation, reliability and attention to detail expected of a premier Swiss brand. And it is all backed by a 100-year legacy of expertise and in-depth understanding of customers' processes, applications and challenges across a wide range of industrial segments, including automotive, medical, electronics and connections, and micromechanics.

Start-up assistance

From the first feasibility tests prior to purchase, you are in good hands with Tornos Service. In our state-of-the-art Techno Centers, expert application engineers support you with tests to gauge the feasibility of machining processes and applications. With start-up assistance, you are secure in the knowledge that you will never be left alone to deal with a brand new machine.

Expert training and coaching

Engineered for intuitive and easy use, Tornos machines offer a vast range of options and enable myriad processes. Expert training and coaching help your employees become programming, handling and maintenance experts, adding more value to your processes, applications and products.

Free Hotline support

Wherever you are in the world, highly qualified specialists who speak your language and understand your processes are just a phone call away to quickly support you with handling and programming solutions.



Discover
Tornos Service

On-site support

Fast, efficient on-site operations and preventive maintenance ensure the continuous high performance of your Tornos machines. Regular scheduled preventive maintenance can help you avoid 70% of machine breakdowns and keep you on the path to productivity.

Certified original spare parts

Rapid, reliable, worldwide delivery of certified original Tornos spare parts is a specialty of Tornos Service. Regardless of the age of the your Tornos machine, we stock the essential certified spare parts to keep the machine running at peak performance.

Machine overhauls

Tornos machines inspire confidence, so it's no surprise that many customers turn to Tornos for complete overhaul of their workhorse machines. Tornos overhaul service returns the machines in good-as-new condition, appreciably extending their longevity.

Options and upgrades

To help you achieve your manufacturing, productivity and quality objectives, our experts collaborate with you to manage complex machining processes, develop software features for machining complex shapes, design special equipment, and tailor peripherals to customers' needs.



Truly best value goes beyond calculations like ROI and total cost of investment to deliver optimal life cycle cost.

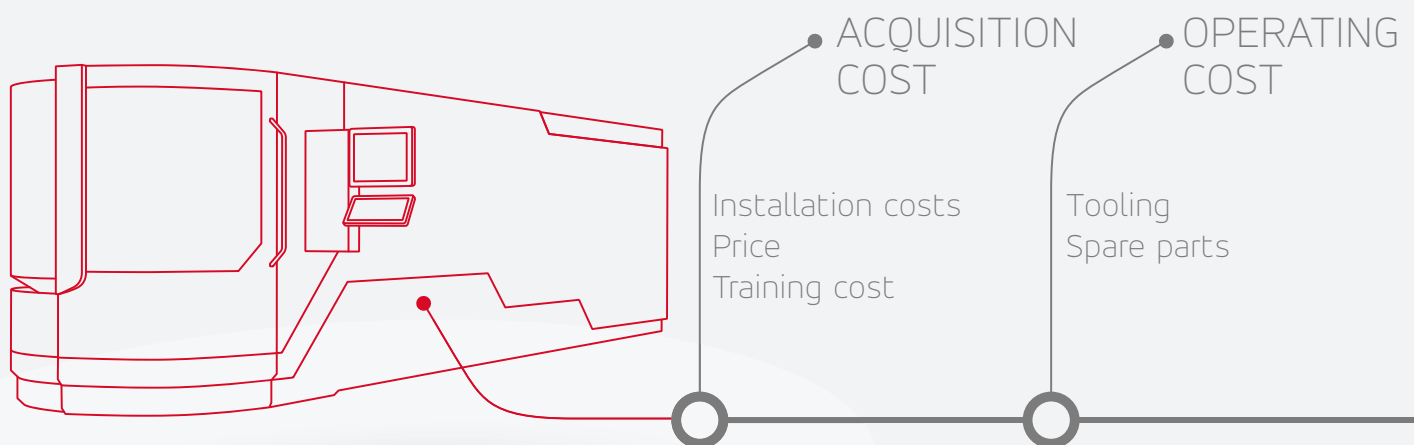

In the face of myriad automotive industry opportunities and challenges, **Tornos keeps suppliers turning solutions that ensure appreciable return on investment (ROI)**. Manufacturers often focus only on equipment price when calculating ROI, not taking into account the total life cycle cost or anticipated performance of the equipment. The price-only philosophy can make you forget the reality, the acquisition, operating, maintenance and decommissioning costs can all affect a machine's true cost.

Tornos solutions continue to serve you well beyond the classical five-year classical amortization period. Our machines are designed to stand years of heavy-duty production.

A low-cost machine is fully depreciated after three or four years, so it looks inexpensive on the accounting books. This type of thinking leads many manufacturers to keep the machine running in the shop long after it should be retired. A lower-cost machine leads to high maintenance costs, insufficient part quality and increased waste of material and parts. After three years, such a machine has minimal value. In contrast, **a high-performance Tornos machine can extend component life and reliability, reduce maintenance costs and retain 50% of its value on the used market at the end of three years**. These benefits should be factored into actual ROI.

IT'S NO WONDER RENOWNED AUTOMOBILE MANUFACTURERS AND THEIR SUPPLY PARTNERS CHOOSE OUR TECHNOLOGIES, PRODUCTS, EXPERTISE AND SERVICES.

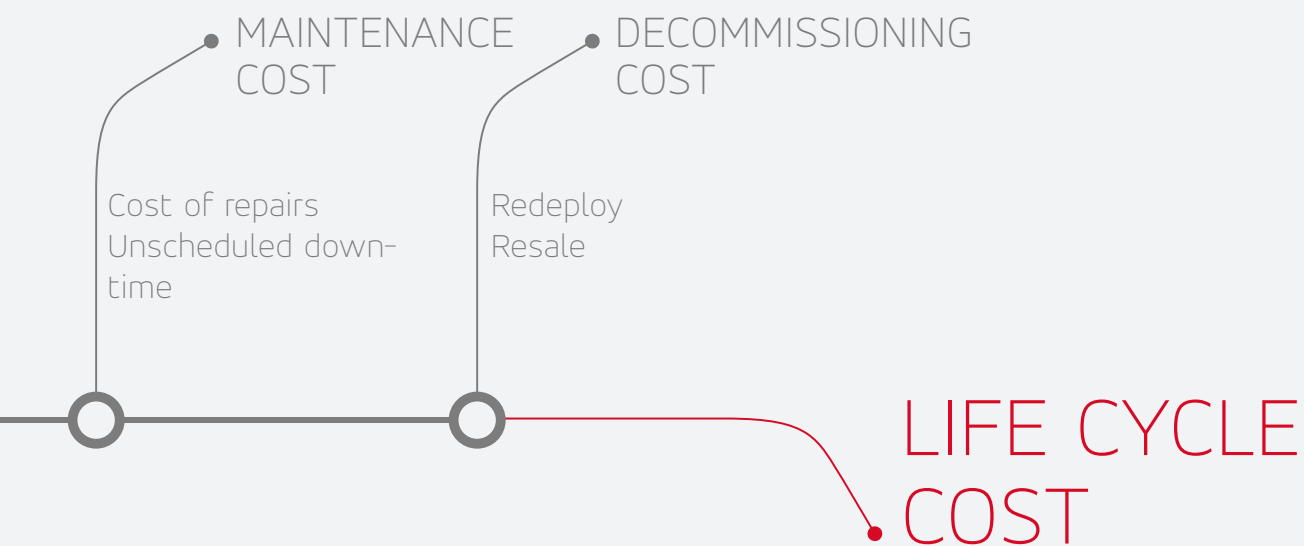

Price is only one facet of a machine's cost, as the life cycle cost model illustrates well:

Costs considered

- Price
- Cycle time

Costs usually ignored:

- Product performance
- Product life cycle
- Financing costs/cash flow
- Tooling
- Unplanned downtime
- Repair costs
- Labor
- Waste
- Redeployment costs
- Administrative costs
- Installation
- Utilities (software, etc.)

We keep you turning



tornos.com

TORNOS LTD

Rue Industrielle 111
CH-2740 Moutier
Phone +41 (0)32 494 44 44
Fax +41 (0)32 494 44 03
contact@tornos.com

Tornos
throughout
the world

